

## MAINTENANCE

The minimum maintenance recommended for a MCP consists of a visual inspection, as well as a periodic operating test.

For the operating test, follow the previously indicated procedure.

## TECHNICAL CHARACTERISTICS

Power supply voltage:	18 ~27 Vdc
Consumption when idle:	10 µA
Consumption in alarm state:	16 mA
Wiring	2-wire. Recommended cross-section AWG 22~14 (IEC1.5mm <sup>2</sup> )
Temperature range:	-10° - +50° C (ambient temperature)
Humidity range:	Relative humidity 10% - 90% without condensation.
Casing material:	ABS
Protection level:	IP42 (indoor installation).
TYPE:	A
Light-emitting indicator:	Operation pilot: Red flashing Alarm: Red permanent
Size:	98 x 95 x 39 mm

## CERTIFICATIONS

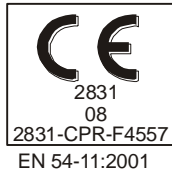

## MANUAL CALL POINT WITH PROTECTIVE COVER MOD.: AGUILERA AE/V-PSAT

Conventional manual call point developed and fabricated according to standard EN 54-11:2001.

This unit is suitable for its installation inside the premises, so that the users can give early warning of a fire. In this way it allows action to be taken when the effect of the fire is in its initial stage.

It incorporates a transparent protective cover to prevent accidental activation.

The design of the manual call point (MCP) allows it to be activated without breaking the pressure pad, it being possible to reset it again by introducing the reset key through the side.

Housed in a red-colored ABS box with dimensions and screen-printing as per standard EN 54-11.

## OPERATION

To actuate the MCP, it is necessary to lift the transparent protective cover and press on the white pad until it engages. A yellow-colored indicator will appear in the bottom part. The MCP will go to the alarm state and activate the red LED in fixed mode.

It includes:

- Operation pilot: It indicates if it is operating correctly, emitting red flashes through the alarm LED.
- Transparent protective cover.
- Pad calibrated to engage and not break screen-printing according to standard EN 54-11:2001.
- Input and output connection terminals.
- Alarm, idle and failure levels for communications with the algorithmic loop.

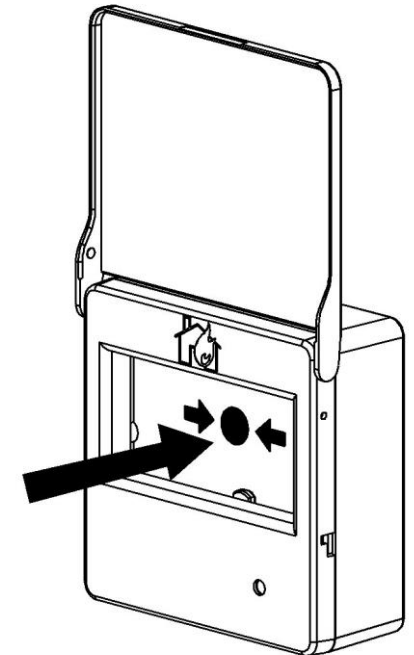

## INSTALLATION

### Assembly

Before installing the MCP it has to be coded as indicated on the last page.

The MCP will generally be installed on the wall, near the emergency exit routes and at a height of 1.2 and 1.5 meters from the floor. (See EN 54-14).

Lift the protective cover and detach the front by introducing the pins of the reset key through the bottom part of the MCP unit and pressing upwards.

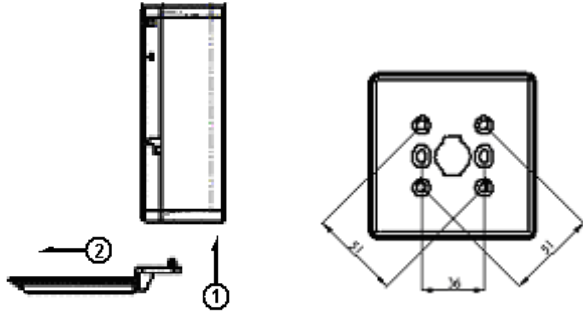

For its installation, fix the MCP box to the wall by means of 2 screws using the fastening openings provided for this purpose, introducing the connection cables through the opening located in the central part of the box. Before installing the MCP unit it has to be coded as indicated on the last page.

### Wiring

Disconnect the supply voltage of the detection loop before installing the MCP.

- Connect the positive input of the detection loop to an L terminal.
- Connect the negative input of the detection loop to a C terminal.
- Connect the positive output of the detection loop to the free L terminal.
- Connect the negative output of the detection loop to the free C terminal.
- If the MCP is the last device of the loop connect the EOL resistor to the L and C free terminals.

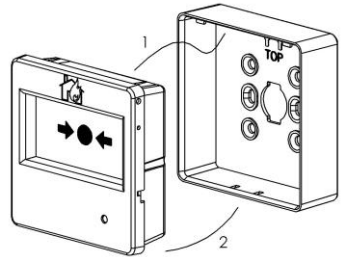
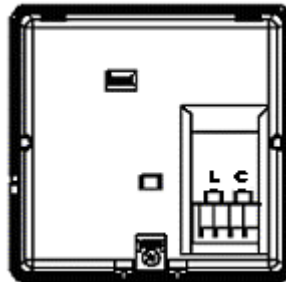

Once the cables have been connected, remount the front of the MCP unit and re-insert it in the box, first the top part by tilting it and making the tabs coincide, and then pressing lightly on the bottom part.

## PRECAUTIONS

- For its installation, follow the recommendations given in the installation standard EN 54-11.
- Try to make the MCP as clearly visible, identifiable and accessible as possible.
- If the MCP is embedded, the right side should be free to be able to insert the reset key.
- Make sure it is firmly secured to the wall.

## VERIFICATION OF OPERATION

The MCP must be tested after installation and undergo periodic maintenance.

Before carrying out the operating tests, notify to the competent authority that maintenance tasks are being carried out in the fire detection system, and make sure that all the evacuation, operation and tripping functions for automatic extinguishing are disabled.

- Check that the MCP is working by observing that the LED emits self-checking flashes. If this does not happen, it means it has failed or the wiring is faulty.
- Activate the manual call point by pressing until the white pad engages, showing the yellow indicator. The MCP will go to the alarm state and activate the red LED in fixed mode.
- The detection loop of the fire panel has to indicate the corresponding alarm. If the panel is reset, the MCP should be indicated again, until the MCP is not reset.
- To reset the MCP, introduce the reset key through the opening on the right side, as indicated in the following figure, until the white pad is disengaged. The yellow indicator will disappear. To reset the system, press the RESET key on the fire control panel.

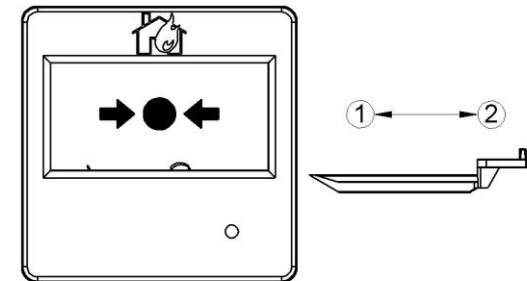

The MCP that do not pass the operating tests should be replaced and repaired.

When the tests have been completed, reconnect the evacuation, operation and extinguishing functions again, and notify the competent authority that the fire detection system is again in service.